

## Power transistor

### Applications

- Linear and swithing industrial equipment

### Description

The TIP32C is a silicon Epitaxial-base PNP power transistor in Jedec TO-220 plastic package. It is intended for use in medium power linear and switching applications.

The complementary NPN type is TIP31C.

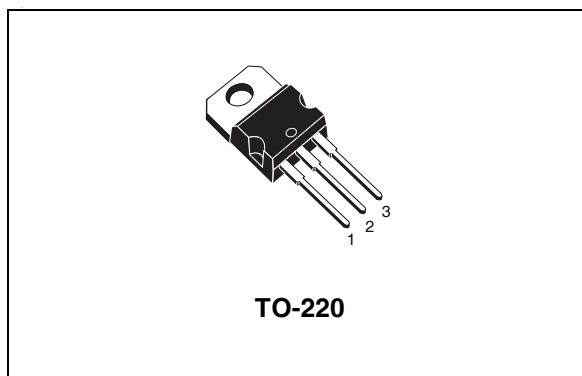

### Internal schematic diagram

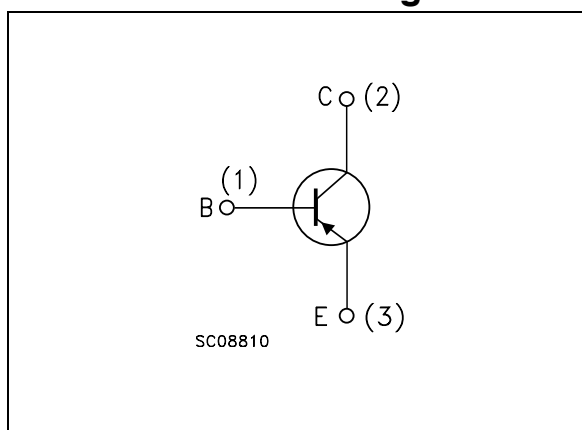

### Order codes

Part number	Marking	Package	Packing
TIP32C	TIP32C	TO-220	Tube

# 1 Absolute maximum ratings

**Table 1. Absolute maximum ratings**

Symbol	Parameter	Value	Unit
$V_{CBO}$	Collector-base voltage ( $I_E = 0$ )	-100	V
$V_{CEO}$	Collector-emitter voltage ( $I_B = 0$ )	-100	V
$V_{EBO}$	Emitter-base voltage ( $I_C = 0$ )	-5	V
$I_C$	Collector current	-3	A
$I_{CM}$	Collector peak current ( $t_P < 5\text{ms}$ )	-5	A
$I_B$	Base current	-1	A
$P_{TOT}$	Total dissipation at $T_{case} = 25^\circ\text{C}$ $T_{amb} = 25^\circ\text{C}$	40	W
		2	W
$T_{stg}$	Storage temperature	-65 to 150	$^\circ\text{C}$
$T_J$	Max. operating junction temperature	150	$^\circ\text{C}$

## 2 Electrical characteristics

( $T_{\text{case}} = 25^{\circ}\text{C}$ ; unless otherwise specified)

**Table 2. Electrical characteristics**

Symbol	Parameter	Test Conditions	Min.	Typ.	Max.	Unit
$I_{\text{CEO}}$	Collector cut-off current ( $I_{\text{B}} = 0$ )	$V_{\text{CB}} = -60\text{V}$			-0.3	mA
$I_{\text{CES}}$	Collector cut-off current ( $V_{\text{BE}} = 0$ )	$V_{\text{CB}} = -100\text{V}$			-0.2	mA
$I_{\text{EBO}}$	Emitter cut-off current ( $I_{\text{C}} = 0$ )	$V_{\text{EB}} = -5\text{V}$			-1	mA
$V_{\text{CEO(sus)}}^{(1)}$	Collector-emitter sustaining voltage ( $I_{\text{B}} = 0$ )	$I_{\text{C}} = -30\text{mA}$	-100			V
$V_{\text{CE(sat)}}^{(1)}$	Collector-emitter saturation voltage	$I_{\text{C}} = -3\text{A}$ $I_{\text{B}} = 375\text{mA}$			-1.2	V
$V_{\text{BE(on)}}^{(1)}$	Base-emitter voltage	$I_{\text{C}} = -3\text{A}$ $V_{\text{CE}} = -4\text{V}$			-1.8	V
$h_{\text{FE}}^{(1)}$	DC current gain	$I_{\text{C}} = -1\text{A}$ $V_{\text{CE}} = -4\text{V}$ $I_{\text{C}} = -3\text{A}$ $V_{\text{CE}} = -4\text{V}$	25 10		50	

1. Pulsed duration = 300 ms, duty cycle  $\geq 1.5\%$ .

### 3 Package Mechanical Data

In order to meet environmental requirements, ST offers these devices in ECOPACK® packages. These packages have a Lead-free second level interconnect . The category of second level interconnect is marked on the package and on the inner box label, in compliance with JEDEC Standard JESD97. The maximum ratings related to soldering conditions are also marked on the inner box label. ECOPACK is an ST trademark.

TO-220 MECHANICAL DATA						
DIM.	mm.			inch		
	MIN.	TYP.	MAX.	MIN.	TYP.	MAX.
A	4.40		4.60	0.173		0.181
b	0.61		0.88	0.024		0.034
b1	1.15		1.70	0.045		0.066
c	0.49		0.70	0.019		0.027
D	15.25		15.75	0.60		0.620
E	10		10.40	0.393		0.409
e	2.40		2.70	0.094		0.106
e1	4.95		5.15	0.194		0.202
F	1.23		1.32	0.048		0.052
H1	6.20		6.60	0.244		0.256
J1	2.40		2.72	0.094		0.107
L	13		14	0.511		0.551
L1	3.50		3.93	0.137		0.154
L20		16.40			0.645	
L30		28.90			1.137	
øP	3.75		3.85	0.147		0.151
Q	2.65		2.95	0.104		0.116

