



**ST901T**

**HIGH VOLTAGE IGNITION COIL DRIVER  
NPN POWER TRANSISTOR**

- n HIGH VOLTAGE SPECIAL DARLINGTON STRUCTURE
- n VERY RUGGED BIPOLAR TECHNOLOGY
- n HIGH OPERATION JUNCTION TEMPERATURE
- n HIGH DC CURRENT GAIN

**APPLICATIONS**

- n HIGH RUGGEDNESS ELECTRONIC IGNITION FOR SMALL ENGINES

**DESCRIPTION**

The ST901T is a High Voltage NPN silicon transistor in monolithic special Darlington configuration mounted in Jedec TO-220 plastic package, designed for applications such as electronic ignition for small engines (scooters, lawnmowers, chainsaws).

**Figure 1: Package**

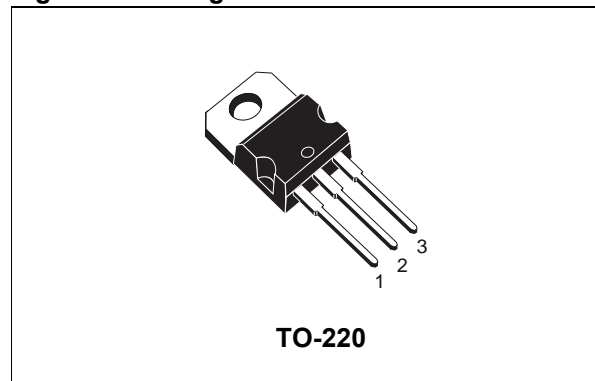

**Figure 2: Internal Schematic Diagram**

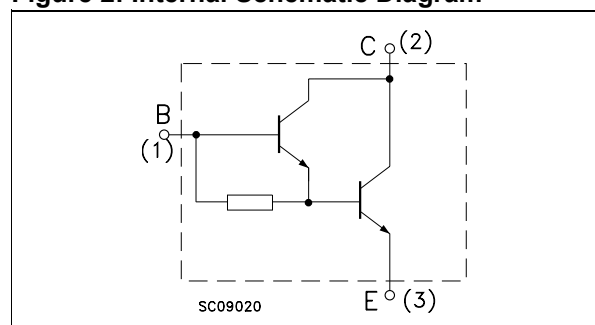

**Table 1: Order Codes**

Part Number	Marking	Package	Packaging
ST901T	901T	TO-220	TUBE

**Table 2: Absolute Maximum Ratings**

Symbol	Parameter	Value	Unit
$V_{CES}$	Collector-Emitter Voltage ( $V_{BE} = 0$ )	500	V
$V_{CEO}$	Collector-Emitter Voltage ( $I_B = 0$ )	350	V
$V_{EBO}$	Emitter-Base Voltage ( $I_C = 0$ )	5	V
$I_C$	Collector Current	4	A
$I_{CM}$	Collector Peak Current ( $t_p < 5ms$ )	8	A
$I_B$	Base Current	0.5	A
$I_{BM}$	Base Peak Current ( $t_p < 5ms$ )	2.5	A
$P_{tot}$	Total Dissipation at $T_C = 25\text{ }^\circ\text{C}$	100	W
$T_{stg}$	Storage Temperature	-65 to 150	$^\circ\text{C}$
$T_J$	Max. Operating Junction Temperature	150	$^\circ\text{C}$

**Table 3: Thermal Data**

$R_{thj-case}$	Thermal Resistance Junction-Case	Max	1.25	$^{\circ}C/W$
----------------	----------------------------------	-----	------	---------------

**Table 4: Electrical Characteristics ( $T_{case} = 25^{\circ}C$  unless otherwise specified)**

Symbol	Parameter	Test Conditions		Min.	Typ.	Max.	Unit
$I_{CES}$	Collector Cut-off Current ( $I_E = 0$ )	$V_{CE} = 500 V$				100	$\mu A$
		$V_{CE} = 500 V$	$T_{case} = 125^{\circ}C$			500	$\mu A$
$I_{CEO}$	Collector Cut-off Current ( $I_B = 0$ )	$V_{CE} = 350 V$				100	$\mu A$
		$V_{CE} = 350 V$	$T_{case} = 125^{\circ}C$			500	$\mu A$
$I_{EBO}$	Emitter Cut-off Current ( $I_C = 0$ )	$V_{EB} = 5 V$				10	$\mu A$
$V_{CEO(sus)}^*$	Collector-Emitter Sustaining Voltage ( $I_B = 0$ )	$I_C = 10 mA$	$L = 10 mH$	350			V
$V_{CE(sat)}^*$	Collector-Emitter Saturation Voltage	$I_C = 2 A$	$I_B = 20 mA$			2	V
$V_{BE(sat)}^*$	Base-Emitter Saturation Voltage	$I_C = 2 A$	$I_B = 20 mA$			1.8	V
$h_{FE}$	DC Current Gain	$I_C = 2 A$	$V_{CE} = 2 V$	1500			
		$I_C = 4 A$	$V_{CE} = 2 V$	500			
	Functional Test	$V_{CC} = 24 V$	$V_{clamp} = 350 V$	4			
		$L = 4 mH$					
$t_s$	INDUCTIVE LOAD Storage Time	$V_{CC} = 12 V$	$V_{clamp} = 250 V$				
		$L = 4 mH$	$I_C = 2 A$		15		$\mu s$
$t_f$	Fall Time	$I_B = 20 mA$	$V_{BE} = -3 V$		1.5		$\mu s$

\* Pulsed: Pulsed duration = 300  $\mu s$ , duty cycle  $\leq 1.5\%$ .

## TO-220 MECHANICAL DATA

DIM.	mm.			inch		
	MIN.	TYP	MAX.	MIN.	TYP.	MAX.
A	4.40		4.60	0.173		0.181
b	0.61		0.88	0.024		0.034
b1	1.15		1.70	0.045		0.066
c	0.49		0.70	0.019		0.027
D	15.25		15.75	0.60		0.620
E	10		10.40	0.393		0.409
e	2.40		2.70	0.094		0.106
e1	4.95		5.15	0.194		0.202
F	1.23		1.32	0.048		0.052
H1	6.20		6.60	0.244		0.256
J1	2.40		2.72	0.094		0.107
L	13		14	0.511		0.551
L1	3.50		3.93	0.137		0.154
L20		16.40			0.645	
L30		28.90			1.137	
øP	3.75		3.85	0.147		0.151
Q	2.65		2.95	0.104		0.116

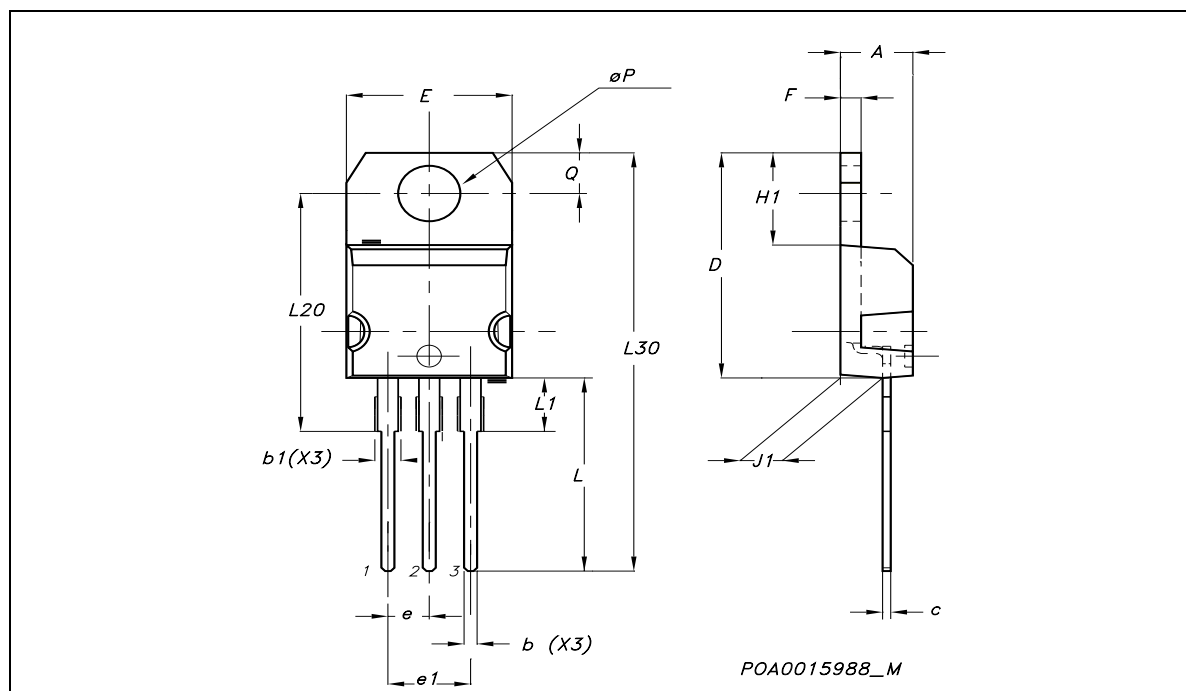

**Figure 5: Revision History**

<b>Version</b>	<b>Release Date</b>	<b>Change Designator</b>
14-Oct-2004	1	First Release.
15-Jan-2005	2	DC current gain range has been modified.

Information furnished is believed to be accurate and reliable. However, STMicroelectronics assumes no responsibility for the consequences of use of such information nor for any infringement of patents or other rights of third parties which may result from its use. No license is granted by implication or otherwise under any patent or patent rights of STMicroelectronics. Specifications mentioned in this publication are subject to change without notice. This publication supersedes and replaces all information previously supplied. STMicroelectronics products are not authorized for use as critical components in life support devices or systems without express written approval of STMicroelectronics.

The ST logo is a registered trademark of STMicroelectronics

All other names are the property of their respective owners

© 2005 STMicroelectronics - All Rights Reserved

STMicroelectronics group of companies

Australia - Belgium - Brazil - Canada - China - Czech Republic - Finland - France - Germany - Hong Kong - India - Israel - Italy - Japan - Malaysia - Malta - Morocco - Singapore - Spain - Sweden - Switzerland - United Kingdom - United States of America

[www.st.com](http://www.st.com)