



**DESCRIPTION** — The SN54LS/74LS348 and the SN54LS/74LS848 are eight input priority encoders which provide the 8-line to 3-line function.

The outputs(A0-A2) and inputs (0-7) are active low. The active low input which has the highest priority(input 7 has the highest) is represented on the outputs (output A0 is the lowest bit). An example would be if inputs 1, 2 and 4 were low, then a binary 4 would be represented on the outputs.

The GS (Group Signal) output is active low when any of the inputs are low. It serves to indicate when any of the inputs are active.

A0, A1 and A2 are three-state outputs. This allows for up to 64 line expansion without the need for special external circuitry.

A logical one on the Enable Input (EI) forces A0, A1 and A2 to the disabled state and outputs GS and EO to the high state. A high on all data inputs (0-7) together with a low on the EI input disables outputs A0, A1, and A2 and forces output GS to the high state and output EO to the low state.

Use of the EI input in conjunction with the EO output provides for the capability of having priority encoding of n input signals.

The LS848 has special internal circuitry providing for a greatly reduced negative going glitch on the GS (Group Signal) output and on a reduced tendency for the A0, A1 and A2 outputs to become momentarily enabled. Both of these occurrences happen when the EI input goes from a logical one to a logical zero and all data inputs (0-7) are held at logical ones. The internal glitch reduction circuitry does add an additional fan-in of one on all data inputs (compared to that of the LS348).

**FUNCTION TABLE**

EI	INPUTS								OUTPUTS				
	0	1	2	3	4	5	6	7	A2	A1	A0	GS	EO
H	X	X	X	X	X	X	X	X	Z	Z	Z	H	H
L	H	H	H	H	H	H	H	H	Z	Z	Z	H	L
L	X	X	X	X	X	X	L	L	L	L	L	H	L
L	X	X	X	X	X	L	H	L	L	H	L	H	L
L	X	X	X	X	L	H	H	L	L	H	L	H	L
L	X	X	X	L	H	H	H	L	L	H	L	H	L
L	X	X	L	H	H	H	H	L	L	H	L	H	L
L	X	X	L	H	H	H	H	H	L	L	H	L	H
L	X	L	H	H	H	H	H	H	L	L	H	L	H
L	L	H	H	H	H	H	H	H	H	L	L	H	H

H = high logic level  
 L = low logic level  
 X = irrelevant  
 Z = high impedance state

# SN54/74LS348 SN54/74LS848

## 8-INPUT PRIORITY ENCODER

LOW POWER SCHOTTKY

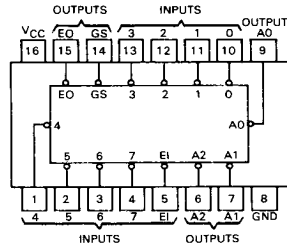

J Suffix — Case 620-09 (Ceramic)  
 N Suffix — Case 648-08 (Plastic)

### BLOCK DIAGRAMS

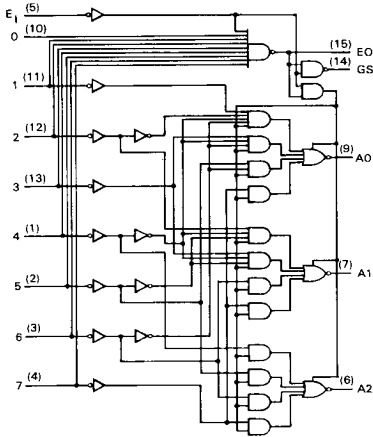

SN54LS/74LS348

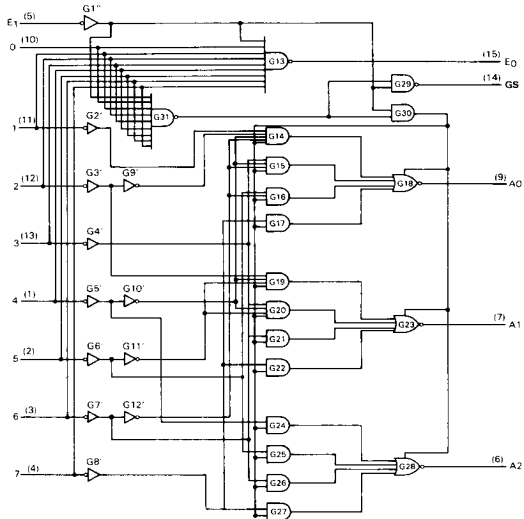

SN54LS/74LS848

**GUARANTEED OPERATING RANGES**

SYMBOL	PARAMETER		MIN	TYP	MAX	UNIT
V <sub>CC</sub>	Supply Voltage	54	4.5	5.0	5.5	V
		74	4.75	5.0	5.25	
T <sub>A</sub>	Operating Ambient Temperature Range	54 74	-55 0	25 25	125 70	°C
I <sub>OH</sub>	Output Current — High EO, GS	54,74			-0.4	mA
I <sub>OH</sub>	Output Current — High A0, A1, A2 A0, A1, A2	54			-1.0	mA
		74			-2.6	
I <sub>OL</sub>	Output Current — Low EO, GS	54			4.0	mA
		74			8.0	
I <sub>OL</sub>	Output Current — Low A0, A1, A2 A0, A1, A2	54			12	mA
		74			24	

**DC CHARACTERISTICS OVER OPERATING TEMPERATURE RANGE** (unless otherwise specified)

SYMBOL	PARAMETER	LIMITS			UNITS	TEST CONDITIONS
		MIN	TYP	MAX		
V <sub>IH</sub>	Input HIGH Voltage	2.0			V	Guaranteed Input HIGH Voltage for All Inputs
V <sub>IL</sub>	Input LOW Voltage	54		0.7	V	Guaranteed Input LOW Voltage for All Inputs
		74		0.8		
V <sub>IK</sub>	Input Clamp Diode Voltage		-0.65	-1.5	V	V <sub>CC</sub> = MIN, I <sub>IN</sub> = -18 mA
V <sub>OH</sub>	Output HIGH Voltage A0, A1, A2 EO, GS EO, GS	54,74	2.4	3.1	V	V <sub>CC</sub> = MIN, I <sub>OH</sub> = MAX, V <sub>IN</sub> = V <sub>IH</sub> or V <sub>IL</sub> per Truth Table
		54	2.5	3.5	V	
		74	2.7	3.5	V	
V <sub>OL</sub>	Output LOW Voltage EO, GS	54,74	0.25	0.4	V	I <sub>OL</sub> = 4.0 mA I <sub>OL</sub> = 8.0 mA V <sub>CC</sub> = V <sub>CC</sub> MIN, V <sub>IN</sub> = V <sub>IL</sub> or V <sub>IH</sub> per Truth Table
		74	0.35	0.5	V	
V <sub>OL</sub>	Output LOW Voltage A0, A1, A2	54,74	0.25	0.4	V	I <sub>OL</sub> = 12 mA I <sub>OL</sub> = 24 mA V <sub>CC</sub> = V <sub>CC</sub> MIN, V <sub>IN</sub> = V <sub>IL</sub> or V <sub>IH</sub> per Truth Table
		74	0.35	0.5	V	
I <sub>IH</sub>	Input HIGH Current Input 0, EI — LS348 Input 0 — LS848 Other — LS348 Other — LS848			20	μA	V <sub>CC</sub> = MAX, V <sub>IN</sub> = 2.7 V
				40	μA	
				40	μA	
				60	μA	
	Input 0, EI — LS348 Input 0 — LS848 Other — LS348 Other — LS848			0.1	mA	V <sub>CC</sub> = MAX, V <sub>IN</sub> = 7.0 V
				0.2	mA	
I <sub>IL</sub>	Input LOW Current Input 0, EI — LS348 Input 0 — LS848 Other — LS348 Other — LS848			-0.4	mA	V <sub>CC</sub> = MAX, V <sub>IN</sub> = 0.4 V
				-0.8	mA	
				-0.8	mA	
				-1.2	mA	
I <sub>OS</sub>	Short Circuit Current EO, GS A0,A1,A2	-20		-120	mA	V <sub>CC</sub> = MAX
		-30		-130	mA	
I <sub>CC</sub>	Power Supply Current Total, Output HIGH Total, Output LOW		12	23	mA	V <sub>CC</sub> = MAX, All Inputs and Outputs Open
			13	25		V <sub>CC</sub> = MAX, Inputs 7, E1 = GND All Others Open

5

FAST AND LS TTL DATA

**AC CHARACTERISTICS:**  $V_{CC} = 5.0\text{ V}$ ,  $T_A = 25^\circ\text{C}$

SYMBOL	FROM (INPUT)	TO (OUTPUT)	WAVEFORM	LS348 LIMITS			LS848 LIMITS			UNIT	TEST CONDITIONS
				MIN	TYP	MAX	MIN	TYP	MAX		
t <sub>PLH</sub>	1 thru 7	A0, A1, or A2	In-Phase output	11	17		12	18	ns	C <sub>L</sub> = 45 pF	
t <sub>PHL</sub>				20	30		20	30			
t <sub>PLH</sub>	1 thru 7	A0, A1, or A2	Out-of-Phase output	23	35		23	35	ns	R <sub>L</sub> = 667 Ω	
t <sub>PHL</sub>				23	35		23	35			
t <sub>PZH</sub>	EI	A0, A1, or A2		25	39		25	39	ns		
t <sub>PZL</sub>				24	41		24	41			
t <sub>PLH</sub>	0 thru 7	EO	Out-of-Phase output	11	18		11	18	ns		
t <sub>PHL</sub>				26	40		26	40			
t <sub>PLH</sub>	0 thru 7	GS	In-Phase output	38	55		38	55	ns	C <sub>L</sub> = 15 pF	
t <sub>PHL</sub>				9.0	21		9.0	21			
t <sub>PLH</sub>	EI	GS	In-Phase output	11	17		11	17	ns	R <sub>L</sub> = 2.0 kΩ	
t <sub>PHL</sub>				14	36		14	36			
t <sub>PLH</sub>	EI	EO	In-Phase output	17	21		17	21	ns		
t <sub>PHL</sub>				25	40		30	45			
t <sub>PHZ</sub>	EI	A0, A1 or A2		18	27		18	27	ns	C <sub>L</sub> = 5.0 pF	
t <sub>PLZ</sub>				23	35		23	35			