

Distributed by:



www.Jameco.com ♦ 1-800-831-4242

The content and copyrights of the attached material are the property of its owner.

Jameco Part Number 1549265

6N135/6

HCNW135/6, HCNW4502/3

HCPL-2502/0452/0453/0500/0501/4502/4503

Single Channel, High Speed Optocouplers



Data Sheet

Description

These diode-transistor optocouplers use an insulating layer between a LED and an integrated photodetector to provide electrical insulation between input and output. Separate connections for the photodiode bias and output-transistor collector increase the speed up to a hundred times that of a conventional phototransistor coupler by reducing the base-collector capacitance.

These single channel optocouplers are available in 8-Pin DIP, SO-8 and Widebody package configurations.

The 6N135, HCPL-0500, and HCNW135 are for use in TTL/CMOS, TTL/LSTTL or wide bandwidth analog applications. Current transfer ratio (CTR) for these devices is 7% minimum at $I_F = 16$ mA.

The 6N136, HCPL-2502, HCPL-0501, and HCNW136 are designed for high speed TTL/TTL applications. A standard 16 mA TTL sink current through the input LED will provide enough output current for 1 TTL load and a 5.6 k Ω pull-up resistor. CTR for these devices is 19% minimum at $I_F = 16$ mA.

Functional Diagram

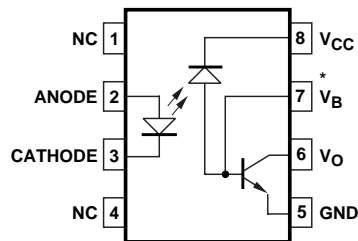

* NOTE: FOR 4502/3, 0452/3, PIN 7 IS NOT CONNECTED.

TRUTH TABLE
(POSITIVE LOGIC)

LED	V_O
ON	LOW
OFF	HIGH

A 0.1 μ F bypass capacitor must be connected between pins 5 and 8.

Features

- 15 kV/ μ s minimum common mode transient immunity at $V_{CM} = 1500$ V (4503/0453)
- High speed: 1 Mb/s
- TTL compatible
- Available in 8-Pin DIP, SO-8, widebody packages
- Open collector output
- Guaranteed performance from temperature: 0°C to 70°C
- Safety approval
 - UL Recognized – 3750 V rms for 1 minute (5000 V rms for 1 minute for HCNW and Option 020 devices) per UL1577
 - CSA Approved
 - IEC/EN/DIN EN 60747-5-2 Approved
 - $V_{IORM} = 630$ V peak for HCPL-4503#060
 - $V_{IORM} = 1414$ V peak for HCNW devices
- Dual channel version available (253X/4534/053X/0534)
- MIL-PRF-38534 hermetic version available (55XX/65XX/4N55)

Applications

- High voltage insulation
- Video signal isolation
- Power transistor isolation in motor drives
- Line receivers
- Feedback element in switched mode power supplies
- High speed logic ground isolation – TTL/TTL, TTL/CMOS, TTL/LSTTL
- Replaces pulse transformers
- Replaces slow phototransistor isolators
- Analog signal ground isolation

CAUTION: It is advised that normal static precautions be taken in handling and assembly of this component to prevent damage and/or degradation which may be induced by ESD.

The HCPL-4502, HCPL-0452, and HCNW4502 provide the electrical and switching performance of the 6N136, HCPL-0501, and HCNW136 with increased ESD protection.

The HCPL-4503, HCPL-0453, and HCNW4503 are similar to the HCPL-4502, HCPL-0452, and HCNW4502 optocouplers but have increased common mode transient immunity of 15 kV/μs minimum at $V_{CM} = 1500$ V guaranteed.

Schematic

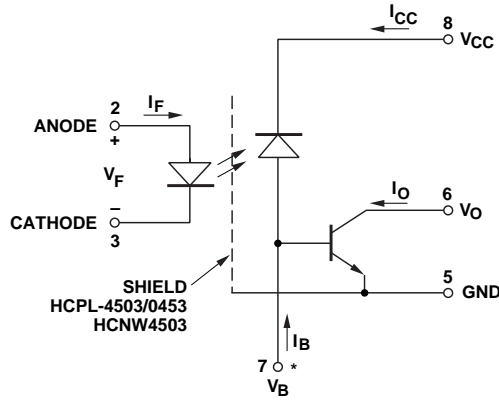

* NOTE: FOR HCPL-4502/-3, HCPL-0452/3, HCNW4502/3, PIN 7 IS NOT CONNECTED.

Selection Guide

Minimum CMR		Current Transfer Ratio (%)	8-Pin DIP (300 Mil)		Small-Outline SO-8		Widebody (400 Mil)	Hermetic
dV/dt (V/μs)	V _{CM} (V)		Single Channel Package	Dual Channel Package*	Single Channel Package	Dual Channel Package*	Single Channel Package	Single and Dual Channel Packages*
1,000	10	7	6N135	HCPL-2530	HCPL-0500	HCPL-0530	HCNW135	
		19	6N136 HCPL-4502†	HCPL-2531	HCPL-0501 HCPL-0452†	HCPL-0531	HCNW136 HCNW4502†	
		15	HCPL-2502					
15,000	1500	19	HCPL-4503†	HCPL-4534	HCPL-0453†	HCPL-0534	HCNW4503†	
1,000	10	9						HCPL-55XX HCPL-65XX 4N55

*Technical data for these products are on separate Avago publications.

†Pin 7, transistor base, is not connected.

Ordering Information

Specify Part Number followed by Option Number (if desired).

Example:

HCPL-4503 #XXXX

- 020 = UL 5000 V rms/1 Minute Option*
- 060 = IEC/EN/DIN EN 60747-5-2 V_{IORM} = 630 V_{peak} Option**
- 300 = Gull Wing Surface Mount Option†
- 500 = Tape and Reel Packaging Option
- XXXE = Lead Free Option

Option data sheets available. Contact your Avago sales representative or authorized distributor for information.

*For 6N135/6 and HCPL-4502/3 only.

**For HCPL-4503 only. Combination of Option 020 and Option 060 is not available.

†Gull wing surface mount option applies to through hole parts only.

Remarks: The notation “#” is used for existing products, while (new) products launched since 15th July 2001 and lead free option will use “-”

Package Outline Drawings

8-Pin DIP Package (6N135/6, HCPL-4502/3, HCPL-2502)

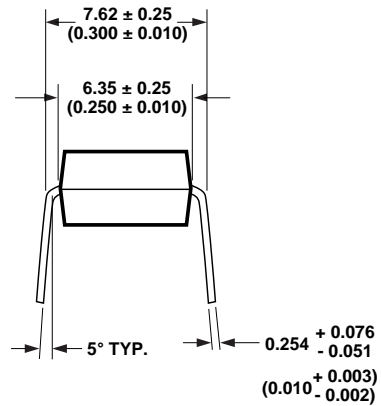
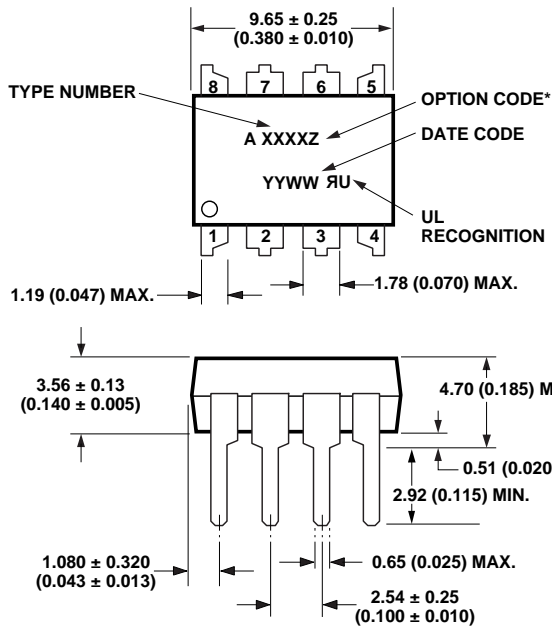

DIMENSIONS IN MILLIMETERS AND (INCHES).
*MARKING CODE LETTER FOR OPTION NUMBERS
"L" = OPTION 020
"V" = OPTION 060
OPTION NUMBERS 300 AND 500 NOT MARKED.

NOTE: FLOATING LEAD PROTRUSION IS 0.25 mm (10 mils) MAX.

8-Pin DIP Package with Gull Wing Surface Mount Option 300 (6N135/6, HCPL-4502/3)

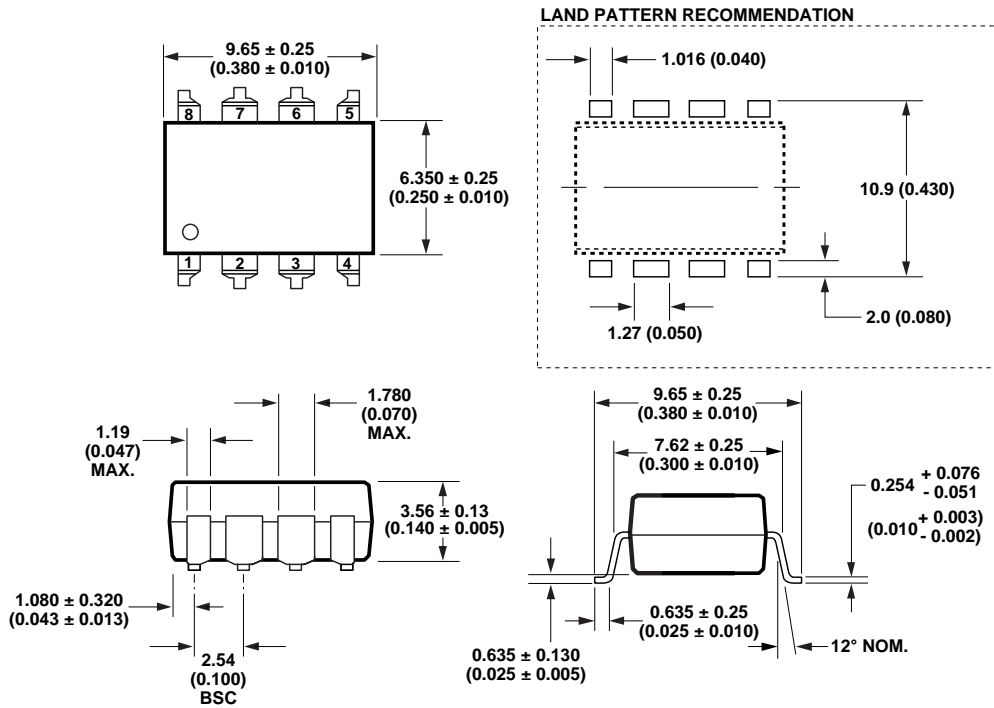

DIMENSIONS IN MILLIMETERS (INCHES).
LEAD COPLANARITY = 0.10 mm (0.004 INCHES).

NOTE: FLOATING LEAD PROTRUSION IS 0.25 mm (10 mils) MAX.

Small Outline SO-8 Package (HCPL-0500/1, HCPL-0452/3)

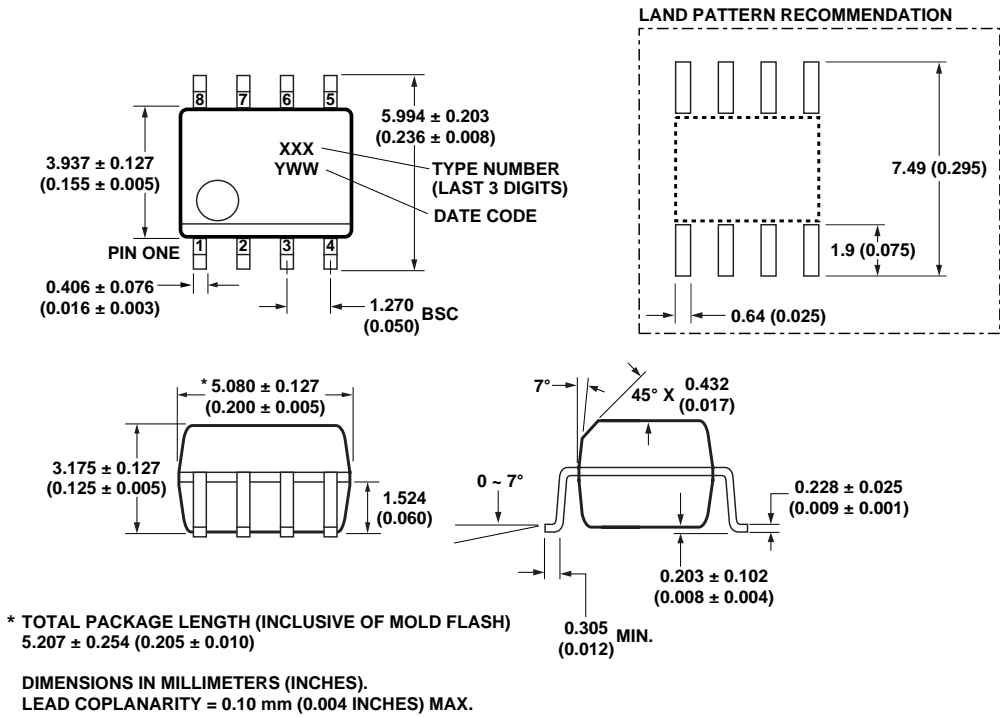

8-Pin Widebody DIP Package (HCNW135/6, HCNW4502/3)

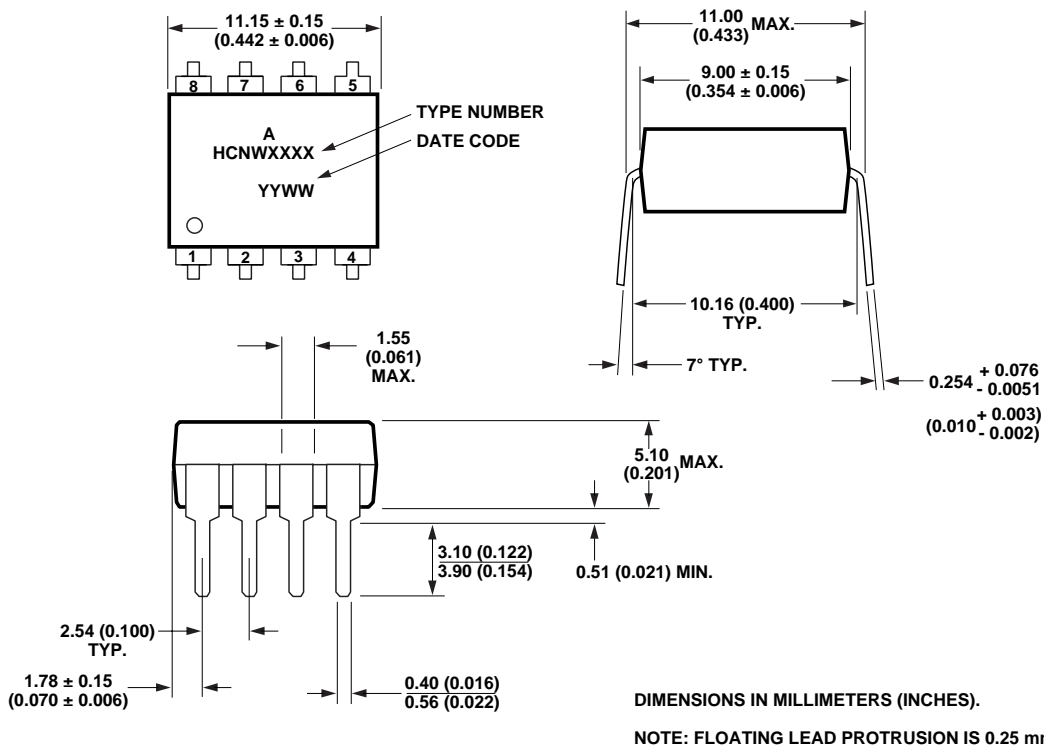

8-Pin Widebody DIP Package with Gull Wing Surface Mount Option 300 (HCNW135/6, HCNW4502/3)

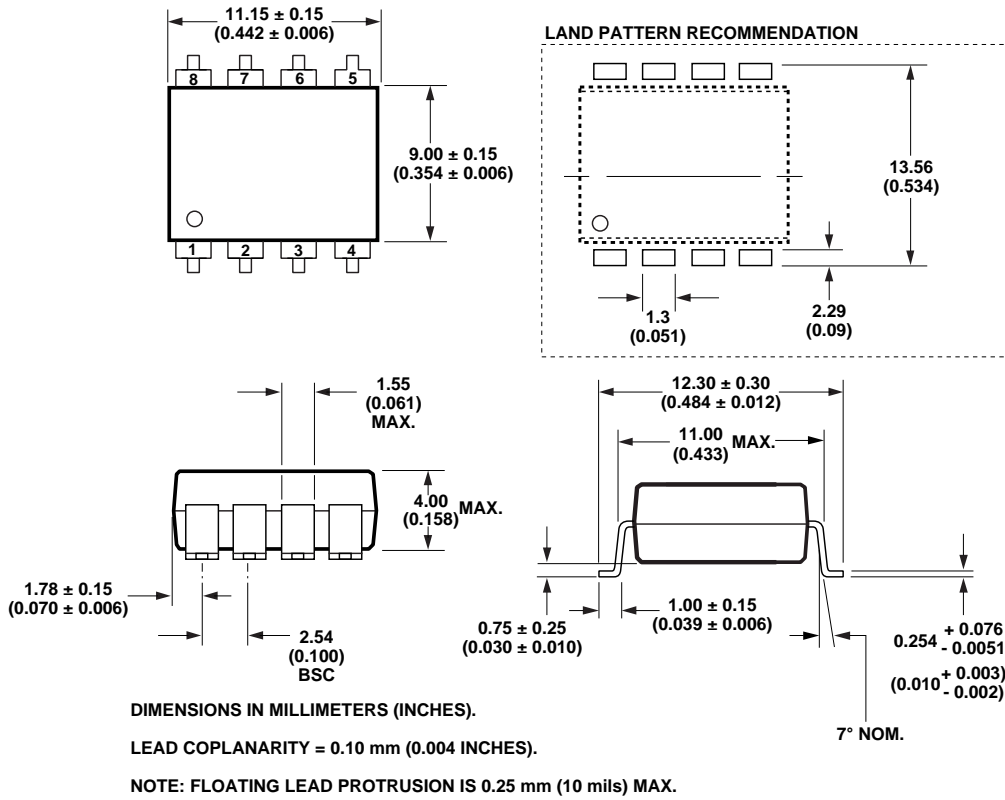

Solder Reflow Temperature Profile

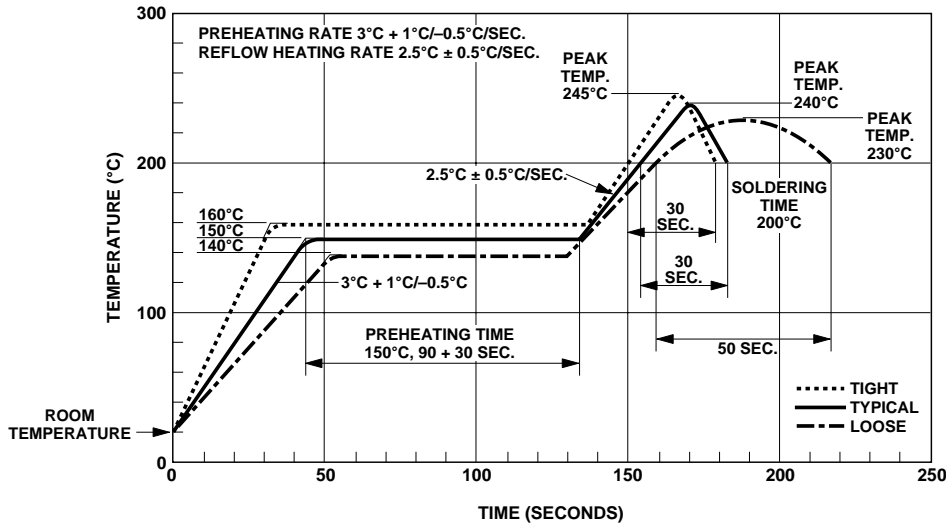

Note: Use of non-chlorine-activated fluxes is highly recommended.

Recommended Pb-Free IR Profile

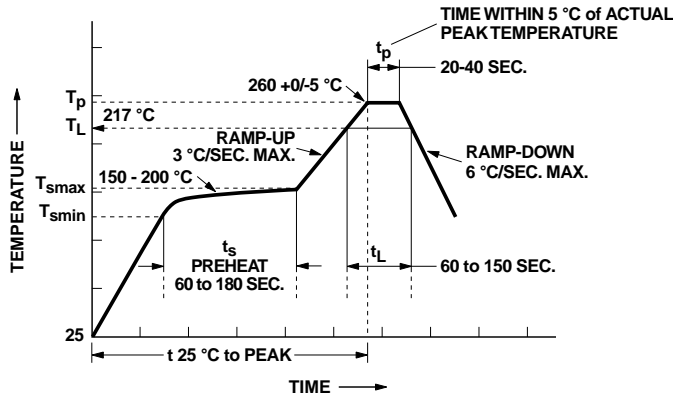

NOTES:
 THE TIME FROM 25 °C TO PEAK TEMPERATURE = 8 MINUTES MAX.
 $T_{smax} = 200\text{ °C}$, $T_{smin} = 150\text{ °C}$

Note: Use of non-chlorine-activated fluxes is highly recommended.

Regulatory Information

The devices contained in this data sheet have been approved by the following organizations:

UL

Recognized under UL 1577, Component Recognition Program, File E55361.

CSA

Approved under CSA Component Acceptance Notice #5, File CA 88324.

IEC/EN/DIN EN 60747-5-2

Approved under IEC 60747-5-2:1997 + A1:2002 EN 60747-5-2:2001 + A1:2002 DIN EN 60747-5-2 (VDE 0884 Teil 2):2003-01 (HCNW and Option 060 only)

Insulation and Safety Related Specifications

Parameter	Symbol	8-Pin DIP (300 Mil) Value	SO-8 Value	Widebody (400 Mil) Value	Units	Conditions
Minimum External Air Gap (External Clearance)	L(101)	7.1	4.9	9.6	mm	Measured from input terminals to output terminals, shortest distance through air.
Minimum External Tracking (External Creepage)	L(102)	7.4	4.8	10.0	mm	Measured from input terminals to output terminals, shortest distance path along body.
Minimum Internal Plastic Gap (Internal Clearance)		0.08	0.08	1.0	mm	Through insulation distance, conductor to conductor, usually the direct distance between the photoemitter and photodetector inside the optocoupler cavity.
Minimum Internal Tracking (Internal Creepage)		NA	NA	4.0	mm	Measured from input terminals to output terminals, along internal cavity.
Tracking Resistance (Comparative Tracking Index)	CTI	200	200	200	Volts	DIN IEC 112/VDE 0303 Part 1
Isolation Group		IIIa	IIIa	IIIa		Material Group (DIN VDE 0110, 1/89, Table 1)

Option 300 - surface mount classification is Class A in accordance with CECC 00802.

IEC/EN/DIN EN 60747-5-2 Insulation Related Characteristics (HCPL-4503 OPTION 060 ONLY)

Description	Symbol	Characteristic	Units
Installation classification per DIN VDE 0110/1.89, Table 1 for rated mains voltage ≤ 300 V rms for rated mains voltage ≤ 450 V rms		I-IV	
		I-III	
Climatic Classification		55/100/21	
Pollution Degree (DIN VDE 0110/1.89)		2	
Maximum Working Insulation Voltage	V_{IORM}	630	V _{peak}
Input to Output Test Voltage, Method b* $V_{IORM} \times 1.875 = V_{PR}$, 100% Production Test with $t_m = 1$ sec, Partial Discharge < 5 pC	V_{PR}	1181	V _{peak}
Input to Output Test Voltage, Method a* $V_{IORM} \times 1.5 = V_{PR}$, Type and sample test, $t_m = 60$ sec, Partial Discharge < 5 pC	V_{PR}	945	V _{peak}
Highest Allowable Overvoltage* (Transient Overvoltage, $t_{ini} = 10$ sec)	V_{IOTM}	6000	V _{peak}
Safety Limiting Values (Maximum values allowed in the event of a failure, also see Figure 9, Thermal Derating curve.) Case Temperature Input Current Output Power	T_S $I_{S,INPUT}$ $P_{S,OUTPUT}$	175 230 600	°C mA mW
Insulation Resistance at T_S , $V_{I0} = 500$ V	R_S	$\geq 10^9$	Ω

IEC/EN/DIN EN 60747-5-2 Insulation Related Characteristics (HCNW135/6, HCNW4502/3 ONLY)

Description	Symbol	Characteristic	Units
Installation classification per DIN VDE 0110/1.89, Table 1 for rated mains voltage ≤ 600 V rms for rated mains voltage ≤ 1000 V rms		I-IV	
		I-III	
Climatic Classification		55/85/21	
Pollution Degree (DIN VDE 0110/1.89)		2	
Maximum Working Insulation Voltage	V_{IORM}	1414	V _{peak}
Input to Output Test Voltage, Method b* $V_{IORM} \times 1.875 = V_{PR}$, 100% Production Test with $t_m = 1$ sec, Partial Discharge < 5 pC	V_{PR}	2652	V _{peak}
Input to Output Test Voltage, Method a* $V_{IORM} \times 1.5 = V_{PR}$, Type and sample test, $t_m = 60$ sec, Partial Discharge < 5 pC	V_{PR}	2121	V _{peak}
Highest Allowable Overvoltage* (Transient Overvoltage, $t_{ini} = 10$ sec)	V_{IOTM}	8000	V _{peak}
Safety Limiting Values (Maximum values allowed in the event of a failure, also see Figure 9, Thermal Derating curve.) Case Temperature Input Current Output Power	T_S $I_{S,INPUT}$ $P_{S,OUTPUT}$	150 400 700	°C mA mW
Insulation Resistance at T_S , $V_{I0} = 500$ V	R_S	$\geq 10^9$	Ω

*Refer to the front of the optocoupler section of the current catalog, under Product Safety Regulations section IEC/EN/DIN EN 60747-5-2, for a detailed description.

Note: Isolation characteristics are guaranteed only within the safety maximum ratings which must be ensured by protective circuits in application.

Absolute Maximum Ratings

Parameter	Symbol	Device	Min.	Max.	Units	Note
Storage Temperature*	T_S		-55	125	°C	
Operating Temperature*	T_A	8-Pin DIP SO-8	-55	100	°C	
		Widebody	-55	85		
Average Forward Input Current*	$I_{F(AVG)}$			25	mA	1
Peak Forward Input Current* (50% duty cycle, 1 ms pulse width) (50% duty cycle, 1 ms pulse width)	$I_{F(PEAK)}$	8-Pin DIP SO-8		50	mA	2
		Widebody		40		
Peak Transient Input Current* ($\leq 1 \mu s$ pulse width, 300 pps)	$I_{F(TRANS)}$	8-Pin DIP SO-8		1	A	
		Widebody		0.1		
Reverse LED Input Voltage* (Pin 3-2)	V_R	8-Pin DIP SO-8		5	V	
		Widebody		3		
Input Power Dissipation*	P_{IN}	8-Pin DIP SO-8		45	mW	3
		Widebody		40		
Average Output Current* (Pin 6)	$I_{O(AVG)}$			8	mA	
Peak Output Current*	$I_{O(PEAK)}$			16	mA	
Emitter-Base Reverse Voltage* (Pin 5-7, except 4502/3, 0452/3)	V_{EBR}			5	V	
Supply Voltage (Pin 8-5)	V_{CC}		-0.5	30	V	
Output Voltage (Pin 6-5)	V_O		-0.5	20	V	
Supply Voltage* (Pin 8-5)	V_{CC}		-0.5	15	V	
Output Voltage* (Pin 6-5)	V_O		-0.5	15	V	
Base Current* (Pin 7, except 4502/3, 0452/3)	I_B			5	mA	
Output Power Dissipation*	P_O			100	mW	4
Lead Solder Temperature* (Through-Hole Parts Only) 1.6 mm below seating plane, 10 seconds up to seating plane, 10 seconds	T_{LS}	8-Pin DIP		260	°C	
		Widebody		260	°C	
Reflow Temperature Profile	T_{RP}	SO-8 and Option 300	See Package Outline Drawings section			

*Data has been registered with JEDEC for the 6N135/6N136.

Electrical Specifications (DC)

Over recommended temperature ($T_A = 0^\circ\text{C}$ to 70°C) unless otherwise specified. See note 13.

Parameter	Symbol	Device	Min.	Typ.**	Max.	Units	Test Conditions			Fig.	Note
Current Transfer Ratio	CTR*	6N135	7	18	50	%	$T_A = 25^\circ\text{C}$	$V_O = 0.4\text{ V}$	$I_F = 16\text{ mA}$, $V_{CC} = 4.5\text{ V}$	1, 2, 4	5, 11
		HCPL-0500	5	19				$V_O = 0.5\text{ V}$			
		HCNW135									
		HCPL-2502	15	25	22		$T_A = 25^\circ\text{C}$	$V_O = 0.4\text{ V}$			
			15	25				$V_O = 0.5\text{ V}$			
			19	24	50		$T_A = 25^\circ\text{C}$	$V_O = 0.4\text{ V}$			
Logic Low Output Voltage	V_{OL}	6N135		0.1	0.4	V	$T_A = 25^\circ\text{C}$	$I_O = 1.1\text{ mA}$	$I_F = 16\text{ mA}$, $V_{CC} = 4.5\text{ V}$		
		HCPL-0500		0.1	0.5			$I_O = 0.8\text{ mA}$			
		HCNW135									
		6N136		0.1	0.4		$T_A = 25^\circ\text{C}$	$I_O = 3.0\text{ mA}$			
		HCPL-2502		0.1	0.5			$I_O = 2.4\text{ mA}$			
		HCPL-4502/3									
HCPL-0501											
HCPL-0452/3											
HCNW136											
HCNW4502/3											
Logic High Output Current	I_{OH}^*			0.003	0.5	μA	$T_A = 25^\circ\text{C}$	$V_O = V_{CC} = 5.5\text{ V}$	$I_F = 0\text{ mA}$	7	
				0.01	1		$T_A = 25^\circ\text{C}$	$V_O = V_{CC} = 15\text{ V}$			
					50			$V_O = V_{CC} = 15\text{ V}$			
Logic Low Supply Current	I_{CCL}			50	200	μA	$I_F = 16\text{ mA}$, $V_O = \text{Open}$, $V_{CC} = 15\text{ V}$			13	
Logic High Supply Current	I_{CCH}^*			0.02	1	μA	$T_A = 25^\circ\text{C}$	$I_F = 16\text{ mA}$, $V_O = \text{Open}$, $V_{CC} = 15\text{ V}$		13	
					2						
Input Forward Voltage	V_F^*	8-Pin DIP SO-8		1.5	1.7	V	$T_A = 25^\circ\text{C}$	$I_F = 16\text{ mA}$		3	
		Widebody	1.45	1.68	1.85		$T_A = 25^\circ\text{C}$				$I_F = 16\text{ mA}$
							1.35				
Input Reverse Breakdown Voltage	BV_R^*	8-Pin DIP SO-8	5			V	$I_R = 10\text{ }\mu\text{A}$				
		Widebody	3				$I_R = 100\text{ }\mu\text{A}$				
Temperature Coefficient of Forward Voltage	$\Delta V_F / \Delta T_A$	8-Pin DIP SO-8		-1.6		mV/ $^\circ\text{C}$	$I_F = 16\text{ mA}$				
		Widebody		-1.9							
Input Capacitance	C_{IN}	8-Pin DIP SO-8		60		pF	$f = 1\text{ MHz}$, $V_F = 0\text{ V}$				
		Widebody		90							
Transistor DC Current Gain	h_{FE}	8-Pin DIP SO-8		150			$V_O = 5\text{ V}$, $I_O = 3\text{ mA}$				
				130			$V_O = 0.4\text{ V}$, $I_B = 20\text{ }\mu\text{A}$				
		Widebody		180			$V_O = 5\text{ V}$, $I_O = 3\text{ mA}$				
				160			$V_O = 0.4\text{ V}$, $I_B = 20\text{ }\mu\text{A}$				

*For JEDEC registered parts.

**All typicals at $T_A = 25^\circ\text{C}$.

Switching Specifications (AC)

Over recommended temperature ($T_A = 0^\circ\text{C}$ to 70°C), $V_{CC} = 5\text{ V}$, $I_F = 16\text{ mA}$ unless otherwise specified.

Parameter	Sym.	Device	Min.	Typ.**	Max.	Units	Test Conditions		Fig.	Note
Propagation Delay Time to Logic Low at Output	t_{PHL}^*	6N135		0.2	1.5	μs	$T_A = 25^\circ\text{C}$	$R_L = 4.1\text{ k}\Omega$	5, 6, 11	8, 9
		HCPL-0500			2.0					
		HCNW135								
		6N136		0.2	0.8		$T_A = 25^\circ\text{C}$	$R_L = 1.9\text{ k}\Omega$		
HCPL-2502			1.0							
HCPL-4502/3										
HCPL-0501										
HCPL-0452/3										
HCNW136										
HCNW4502/3										
Propagation Delay Time to Logic High at Output	t_{PLH}^*	6N135		1.3	1.5	μs	$T_A = 25^\circ\text{C}$	$R_L = 4.1\text{ k}\Omega$	5, 6, 11	8, 9
		HCPL-0500			2.0					
		HCNW135								
		6N136		0.6	0.8		$T_A = 25^\circ\text{C}$	$R_L = 1.9\text{ k}\Omega$		
HCPL-2502			1.0							
HCPL-4502/3										
HCPL-0501										
HCPL-0452/3										
HCNW136										
HCNW4502/3										
Common Mode Transient Immunity at Logic High Level Output	$ CM_H $	6N135		1		$\text{kV}/\mu\text{s}$	$R_L = 4.1\text{ k}\Omega$	$I_F = 0\text{ mA}$, $T_A = 25^\circ\text{C}$, $V_{CM} = 10\text{ V}_{p-p}$, $C_L = 15\text{ pF}$	12	7, 8, 9
		HCPL-0500					$R_L = 1.9\text{ k}\Omega$			
		HCNW135								
6N136		1								
HCPL-2502										
HCPL-4502										
HCPL-0501										
HCPL-0452										
HCNW4502										
HCPL-4503	15	30				$R_L = 1.9\text{ k}\Omega$	$I_F = 0\text{ mA}$, $T_A = 25^\circ\text{C}$, $V_{CM} = 1500\text{ V}_{p-p}$, $C_L = 15\text{ pF}$			
HCPL-0453										
HCNW4503										
Common Mode Transient Immunity at Logic Low Level Output	$ CM_L $	6N135		1		$\text{kV}/\mu\text{s}$	$R_L = 4.1\text{ k}\Omega$	$I_F = 16\text{ mA}$, $T_A = 25^\circ\text{C}$, $V_{CM} = 10\text{ V}_{p-p}$, $C_L = 15\text{ pF}$	12	7, 8, 9
		HCPL-0500					$R_L = 1.9\text{ k}\Omega$			
		HCNW135								
6N136		1								
HCPL-2502										
HCPL-4502										
HCPL-0501										
HCPL-0452										
HCNW4502										
HCPL-4503	15	30				$R_L = 1.9\text{ k}\Omega$	$I_F = 16\text{ mA}$, $T_A = 25^\circ\text{C}$, $V_{CM} = 1500\text{ V}_{p-p}$, $C_L = 15\text{ pF}$			
HCPL-0453										
HCNW4503										
Bandwidth	BW	6N135/6		9		MHz	See Test Circuit		8, 10	10
		HCPL-2502								
HCPL-0500/1										
HCNW135/6			11							

*For JEDEC registered parts.

**All typicals at $T_A = 25^\circ\text{C}$.

Package Characteristics

Over recommended temperature ($T_A = 0^\circ\text{C}$ to 70°C) unless otherwise specified.

Parameter	Sym.	Device	Min.	Typ.*	Max.	Units	Test Conditions	Fig.	Note	
Input-Output Momentary Withstand Voltage**	V_{ISO}	8-Pin DIP SO-8	3750			V rms	RH < 50%, t = 1 min., $T_A = 25^\circ\text{C}$		6, 14	
		Widebody	5000						6, 15	
		8-Pin DIP (Option 020)	5000						6, 12, 15	
	I_{I-O}	8-Pin DIP			1	μA	45% RH, t = 5 s, $V_{I-O} = 3 \text{ kVdc}$, $T_A = 25^\circ\text{C}$		6, 16	
Input-Output Resistance	R_{I-O}	8-Pin DIP SO-8		10^{12}		Ω	$V_{I-O} = 500 \text{ Vdc}$		6	
		Widebody	10^{12}	10^{13}						$T_A = 25^\circ\text{C}$
			10^{11}							$T_A = 100^\circ\text{C}$
Input-Output Capacitance	C_{I-O}	8-Pin DIP SO-8		0.6		pF	f = 1 MHz		6	
		Widebody		0.5	0.6					

*All typicals at $T_A = 25^\circ\text{C}$.

**The Input-Output Momentary Withstand Voltage is a dielectric voltage rating that should not be interpreted as an input-output continuous voltage rating. For the continuous voltage rating refer to the IEC/EN/DIN EN 60747-5-2 Insulation Related Characteristics Table (if applicable), your equipment level safety specification or Avago Application Note 1074 entitled "Optocoupler Input-Output Endurance Voltage," publication number 5963-2203E.

Notes:

- Derate linearly above 70°C free-air temperature at a rate of $0.8 \text{ mA}/^\circ\text{C}$ (8-Pin DIP).
Derate linearly above 85°C free-air temperature at a rate of $0.5 \text{ mA}/^\circ\text{C}$ (SO-8).
- Derate linearly above 70°C free-air temperature at a rate of $1.6 \text{ mA}/^\circ\text{C}$ (8-Pin DIP).
Derate linearly above 85°C free-air temperature at a rate of $1.0 \text{ mA}/^\circ\text{C}$ (SO-8).
- Derate linearly above 70°C free-air temperature at a rate of $0.9 \text{ mW}/^\circ\text{C}$ (8-Pin DIP).
Derate linearly above 85°C free-air temperature at a rate of $1.1 \text{ mW}/^\circ\text{C}$ (SO-8).
- Derate linearly above 70°C free-air temperature at a rate of $2.0 \text{ mW}/^\circ\text{C}$ (8-Pin DIP).
Derate linearly above 85°C free-air temperature at a rate of $2.3 \text{ mW}/^\circ\text{C}$ (SO-8).
- CURRENT TRANSFER RATIO in percent is defined as the ratio of output collector current, I_O , to the forward LED input current, I_F , times 100.
- Device considered a two-terminal device: Pins 1, 2, 3, and 4 shorted together and Pins 5, 6, 7, and 8 shorted together.
- Common mode transient immunity in a Logic High level is the maximum tolerable (positive) dV_{CM}/dt on the leading edge of the common mode pulse signal, V_{CM} , to assure that the output will remain in a Logic High state (i.e., $V_O > 2.0 \text{ V}$). Common mode transient immunity in a Logic Low level is the maximum tolerable (negative) dV_{CM}/dt on the trailing edge of the common mode pulse signal, V_{CM} , to assure that the output will remain in a Logic Low state (i.e., $V_O < 0.8 \text{ V}$).
- The $1.9 \text{ k}\Omega$ load represents 1 TTL unit load of 1.6 mA and the $5.6 \text{ k}\Omega$ pull-up resistor.
- The $4.1 \text{ k}\Omega$ load represents 1 LSTTL unit load of 0.36 mA and $6.1 \text{ k}\Omega$ pull-up resistor.
- The frequency at which the ac output voltage is 3 dB below its mid-frequency value.
- The JEDEC registration for the 6N136 specifies a minimum CTR of 15%. Avago guarantees a minimum CTR of 19%.
- See Option 020 data sheet for more information.
- Use of a $0.1 \mu\text{F}$ bypass capacitor connected between pins 5 and 8 is recommended.
- In accordance with UL 1577, each optocoupler is proof tested by applying an insulation test voltage $\geq 4500 \text{ V rms}$ for 1 second (leakage detection current limit, $I_{I-O} \leq 5 \mu\text{A}$). This test is performed before the 100% Production test shown in the IEC/EN/DIN EN 60747-5-2 Insulation Related Characteristics Table if applicable.
- In accordance with UL 1577, each optocoupler is proof tested by applying an insulation test voltage $\geq 6000 \text{ V rms}$ for 1 second (leakage detection current limit, $I_{I-O} \leq 5 \mu\text{A}$). This test is performed before the 100% Production test shown in the IEC/EN/DIN EN 60747-5-2 Insulation Related Characteristics Table if applicable.
- This rating is equally validated by an equivalent ac proof test.

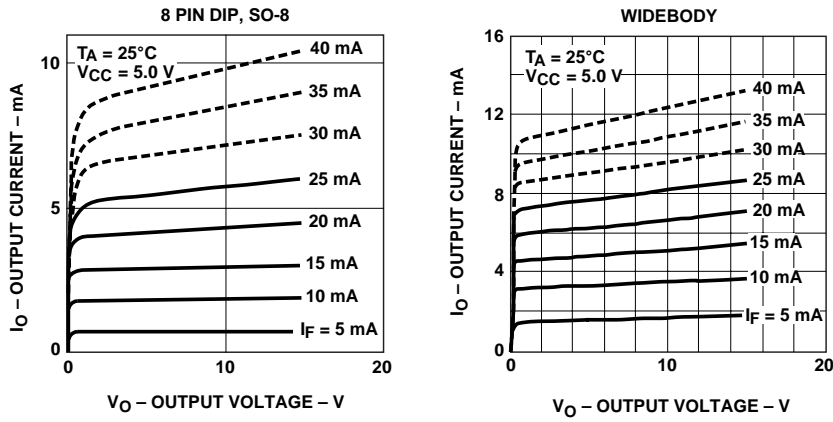

Figure 1. DC and pulsed transfer characteristics.

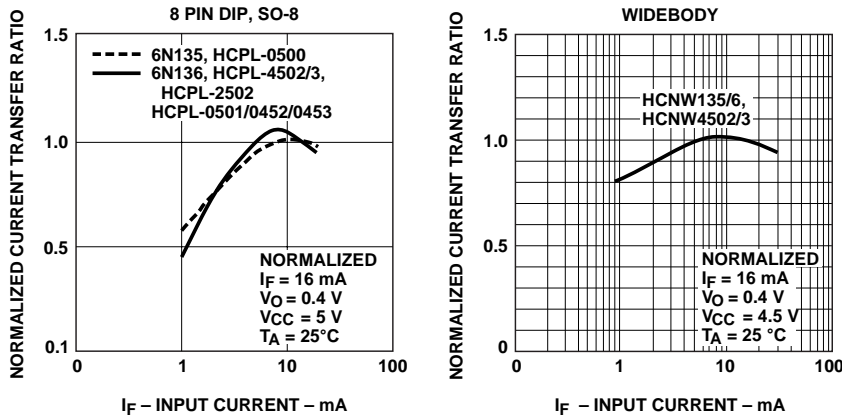

Figure 2. Current transfer ratio vs. input current.

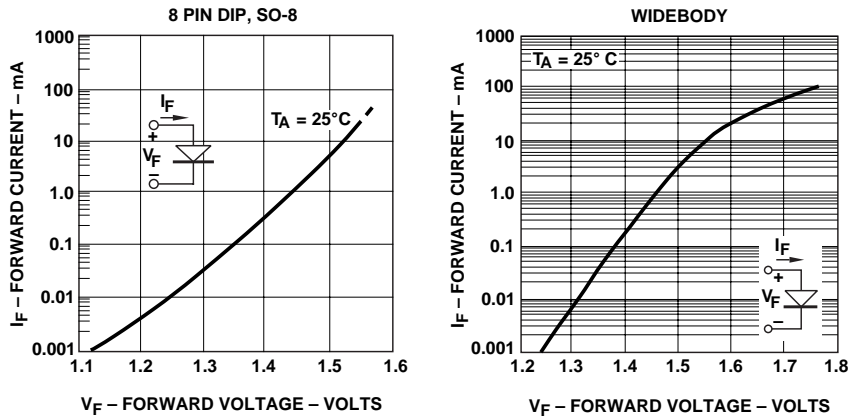

Figure 3. Input current vs. forward voltage.

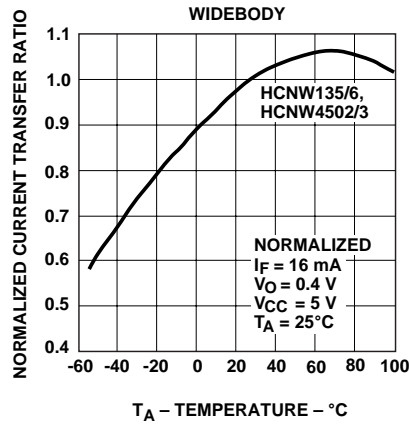
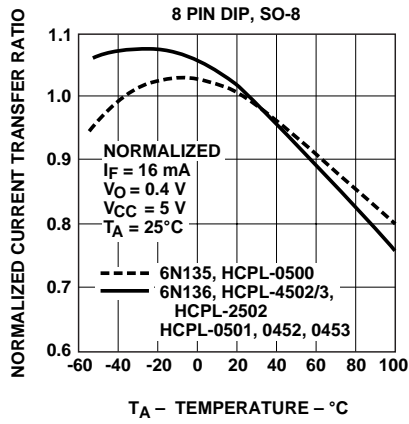

Figure 4. Current transfer ratio vs. temperature.

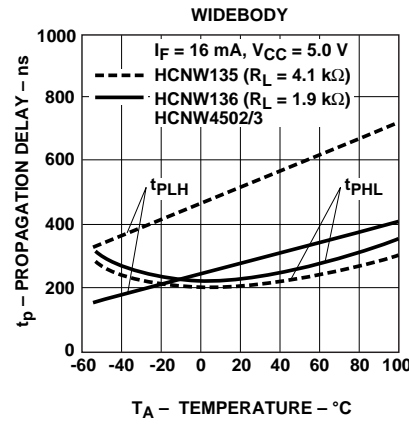
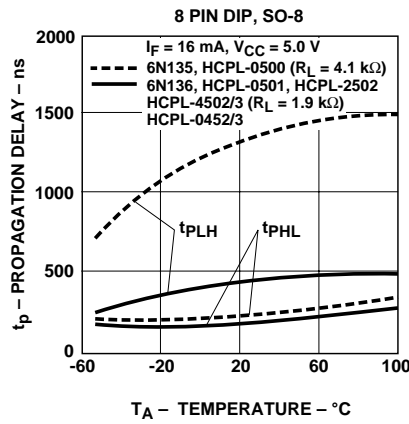

Figure 5. Propagation delay vs. temperature.

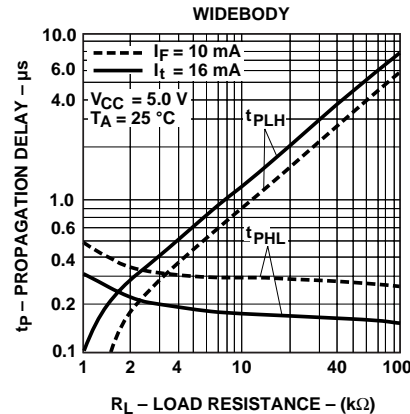
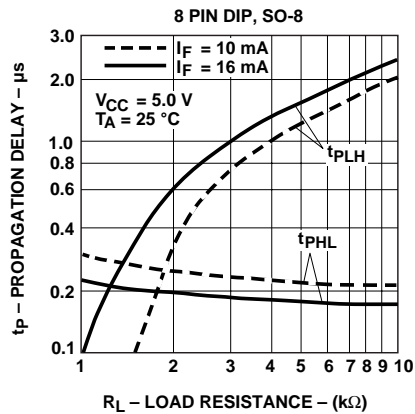

Figure 6. Propagation delay time vs. load resistance.

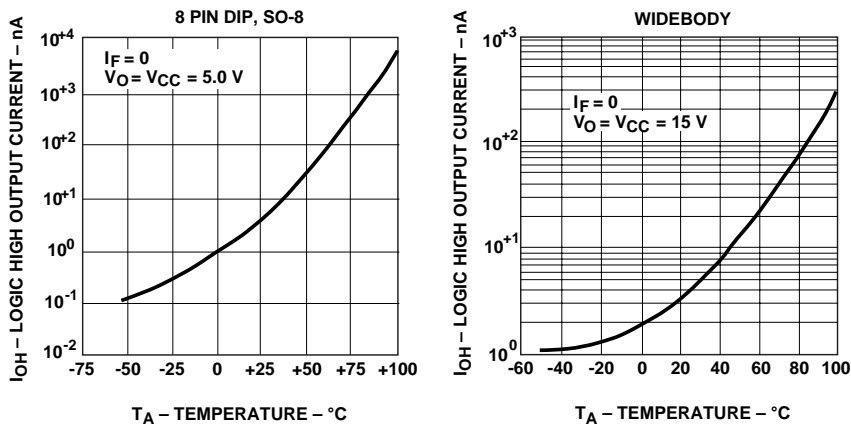

Figure 7. Logic high output current vs. temperature.

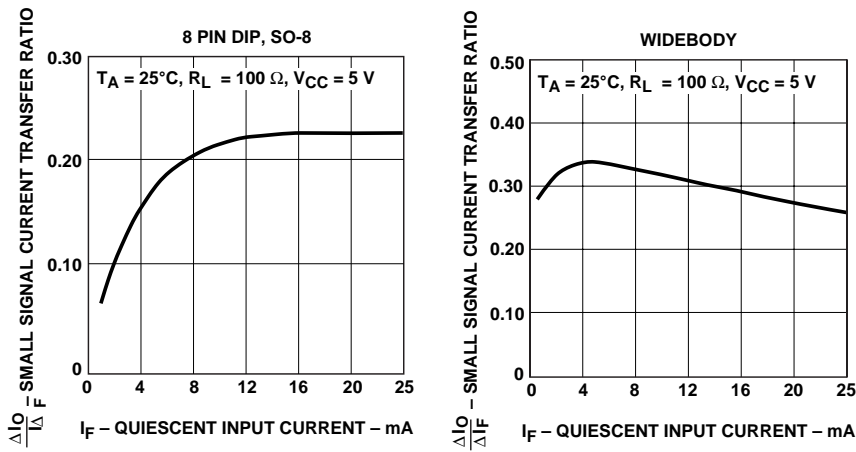

Figure 8. Small-signal current transfer ratio vs. quiescent input current.

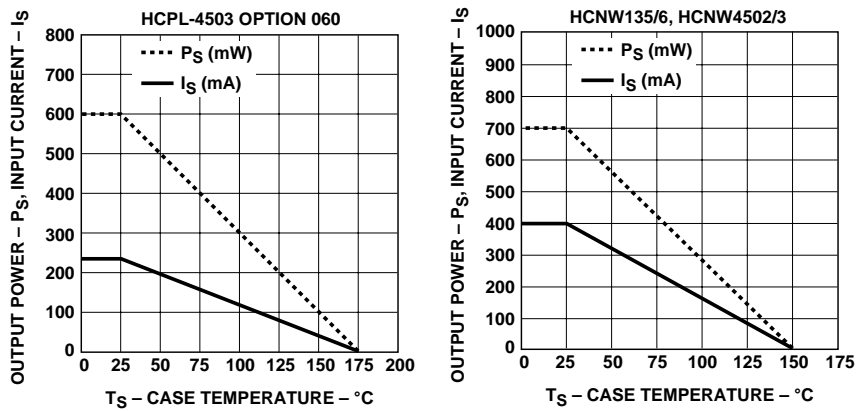

Figure 9. Thermal derating curve, dependence of safety limiting value with case temperature per IEC/EN/DIN EN 60747-5-2.

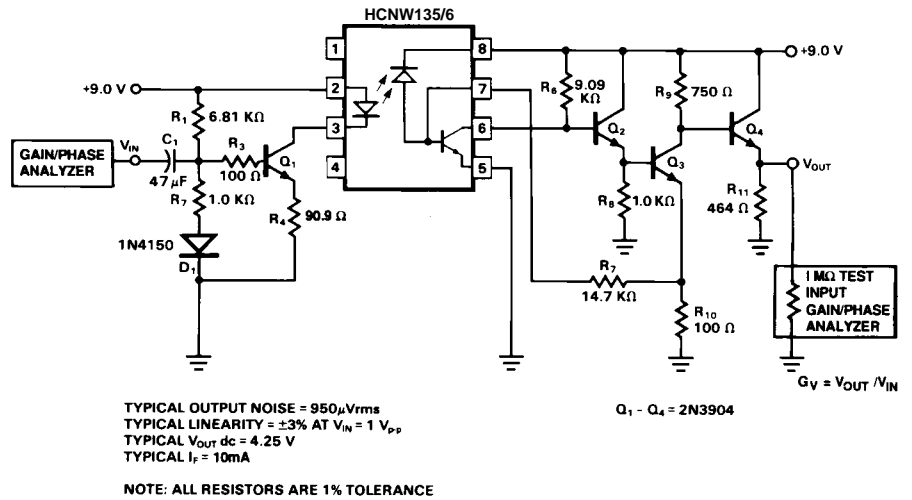
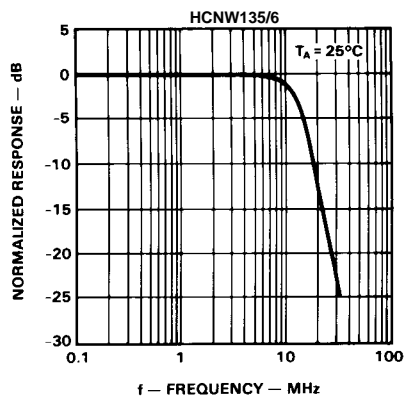
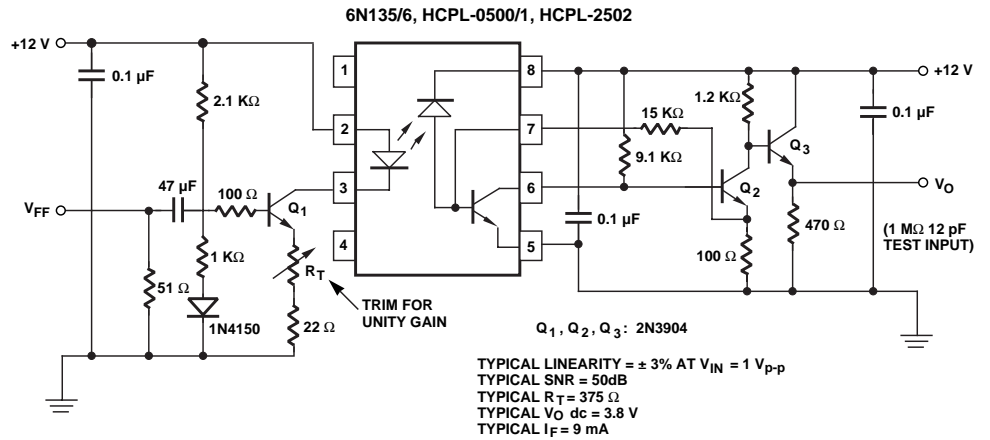
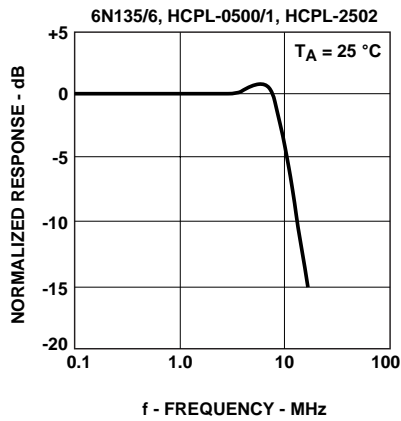

Figure 10. Frequency response.

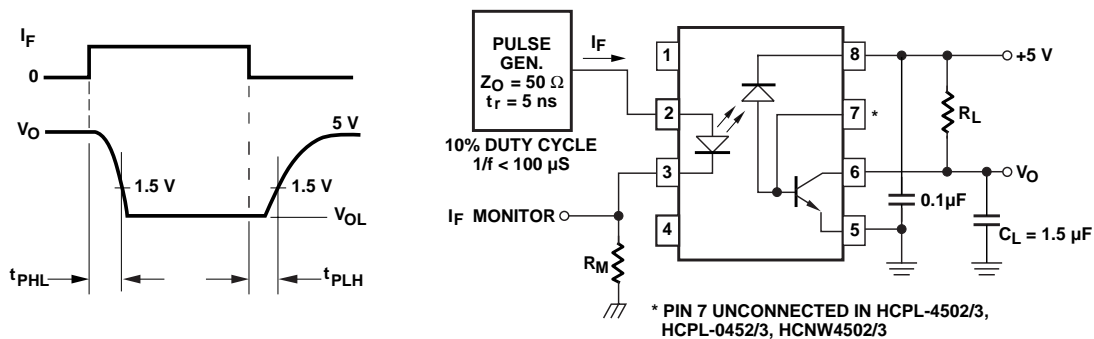

Figure 11. Switching test circuit.

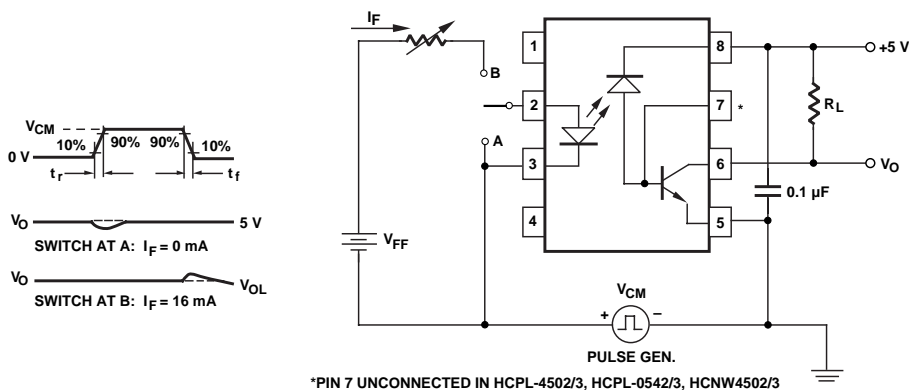

Figure 12. Test circuit for transient immunity and typical waveforms.

For product information and a complete list of distributors, please go to our website: www.avagotech.com

Avago, Avago Technologies, and the A logo are trademarks of Avago Technologies Limited in the United States and other countries. Data subject to change. Copyright © 2006 Avago Technologies Limited. All rights reserved. Obsoletes 5989-2112EN AV01-0550EN October 10, 2006

