

FEATURES

- High Vceo (60Volts)
- UL approval E196140
- Current Transfer Ratios (50% to 600% grade selectable)
- High Isolation Voltage between LED and Opto Transistor (3750Volts)
- Mini-flat Surface mount Package

GENERAL DESCRIPTION

The AMC181 High Voltage Opto Coupler may be used in a variety of applications where high isolation is required between primary and secondary circuits. The Opto-Transistor side of the AMC181 is capable of withstanding Vce Voltages of up to 60Volts without sustaining damage to the device.

Designed for use in telecommunications and data communications equipment the AMC181 opto coupler is an ideal replacement for the industry standard TLP181 device, with matching characteristics.

The AMC181 fits inside the standard footprint for mini-flat opto couplers and may be used as a drop in replacement for designs

already using the Toshiba TLP181 component.

When sited in a line interface circuit behind an AMC127 as the main line seize component, the AMC181 device is ideal for switching telecommunications circuits from relatively low currents flowing in the LED.

The AMC181 device is packaged in a black, rather than the industry standard white housing, making the AMC181 device less sensitive to background ambient light levels.

As with all our devices, Alpha Micro Components offers full engineering support on designs using the AMC181.

4-pin Mini-Flat Package

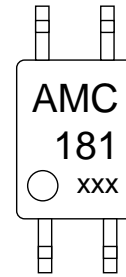

AMC181 Package outline

APPLICATIONS

- Telephone sets
- Data modem line interface circuits.
- Photo-Copiers
- Fax machines
- Switched mode power supply control
- Linear power supply control / sensing
- High density surface mount systems
- Ideal for use in the Alpha Micro Components "High sensitivity" line-in-use voltage detection circuit.

BLOCK DIAGRAM

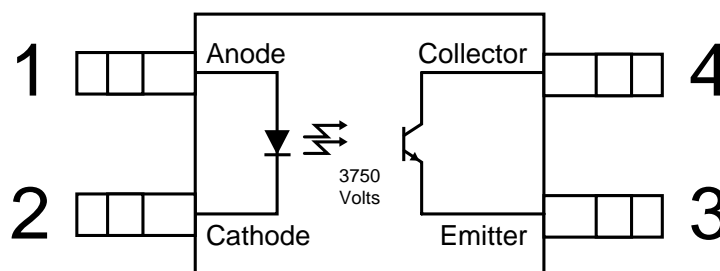

DC, ac, & Isolation Characteristics

• Absolute Maximum Ratings (Ta = 25 °C)

	Parameter	Symbol	Rating	Unit
Input	Forward current	If	50	mA
	Peak forward current	Ifm	1	A
	Reverse voltage	Vr	6	V
	Power dissipation	P	70	mW
Output	Collector-Emitter voltage	Vceo	60	V
	Emitter-collector voltage	Veco	5.0	V
	Collector current	Ic	50	mA
	Collector power dissipation	Pc	150	mW
	Total power dissipation	Ptot	170	mW
	Isolation voltage 1 minute	Viso	3750	Vrms
	Operating temperature	Topr	-30 to +100	°C
	Storage temperature	Tstg	-40 to +125	°C
	Soldering temperature 10 seconds	Tsol	260	°C

• Electrical / Optical Characteristics (Ta = 25 °C)

	Parameter	Symbol	Conditions	MIN.	TYP.	MAX.	Unit
Input	Forward voltage	Vf	If=20mA	-	1.2	1.4	V
	Reverse voltage	Ir	Vr=4V	-	-	10	µA
	Terminal capacitance	Ct	V=0, f=1kHz	-	30	250	pF
Output	Collector dark current	Iceo	Vce=200V, If=0	-	-	0.1	µA
	Collector-emitter breakdown voltage	BVceo	Ic=0.1mA, If=0	60	-	-	V
	Emitter-collector breakdown voltage	BVeco	Ic=100µA, If=0	5	-	-	V
CTR%	NO GRADE	CTR	If=5mA, Vce=5V	50	-	600	%
	GRADE : A	CTR	If=5mA, Vce=5V	100	-	600	%
Transfer Characteristics	Collector-emitter saturation voltage	Vce(sat)	If=20mA, Ic=1mA	-	0.1	0.3	V
	Isolation resistance	Riso	DC500, 40to60%RH	5e10	10e11	-	Ohm
	Floating capacitance	Cf-	0.6 V=0, f=1MHz	-	0.6	1.0	pF
	Response time (rise)	Tr	Vcc=2V, Ic=20mA	-	5	20	µs
	Response time (fall)	Tf	Rl=100Ohm	-	4	20	µs

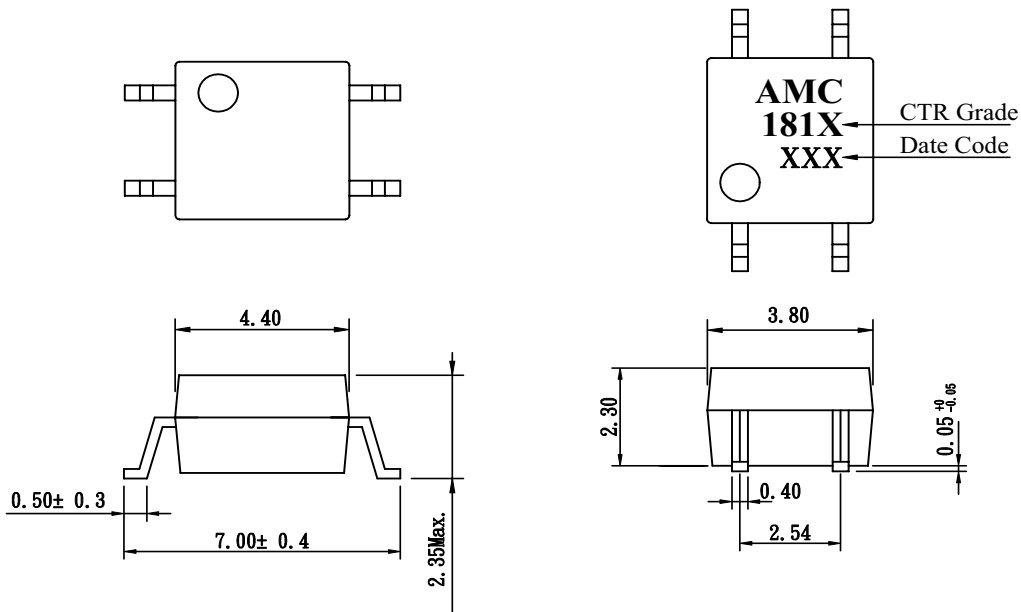

Operational Graphs

Forward Current vs Ambient Temperature

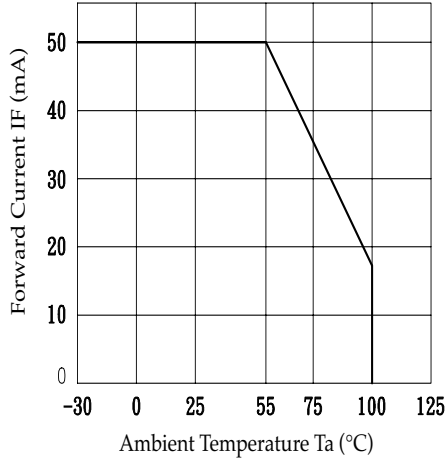

Diode Power vs. Ambient Temperature

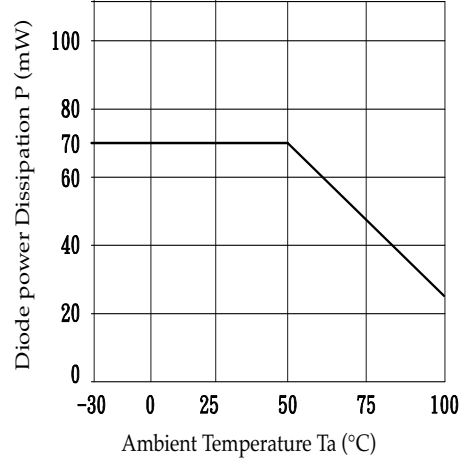

Collector Power Dissipation vs. Ambient Temperature

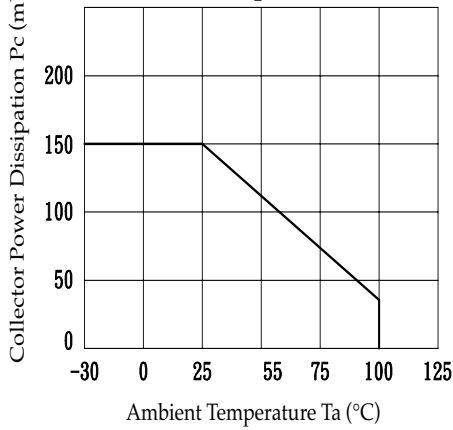

Total Power Dissipation vs. Ambient Temperature

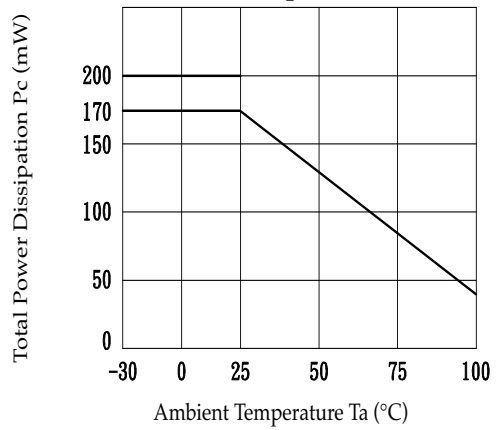

Peak Forward Current vs. Duty Ratio

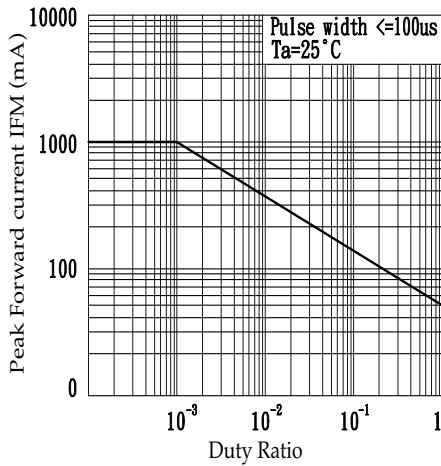

Forward Current vs. Forward Voltage

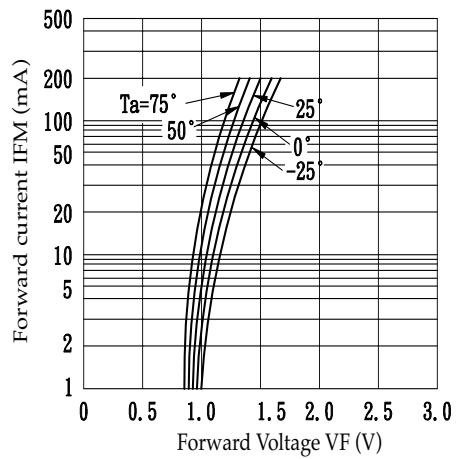

Current Transfer Ratio vs. Forward Current

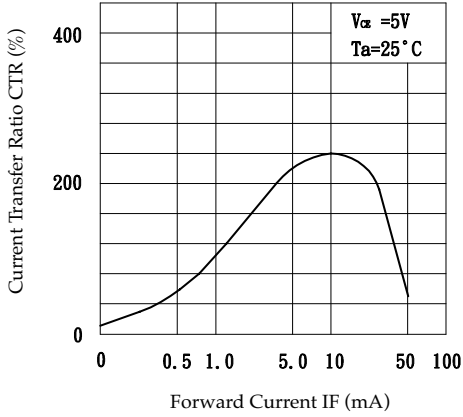

Collector Current vs. Collector-Emitter Voltage

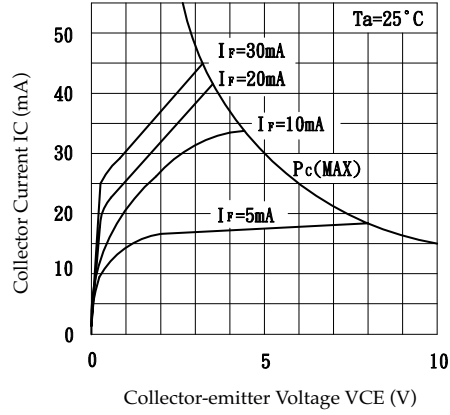

Relative Current Transfer Ratio vs. Ambient Temperature

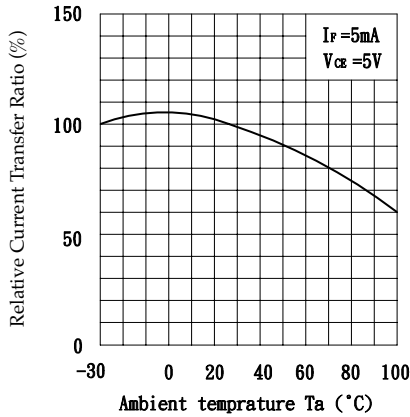

Collector Emitter Saturation Voltage vs. Ambient Temperature

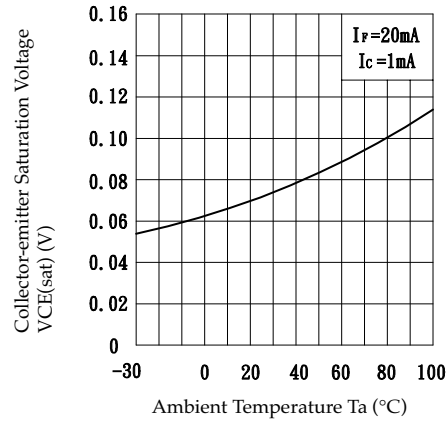

Collector Dark Current vs. Ambient Temperature

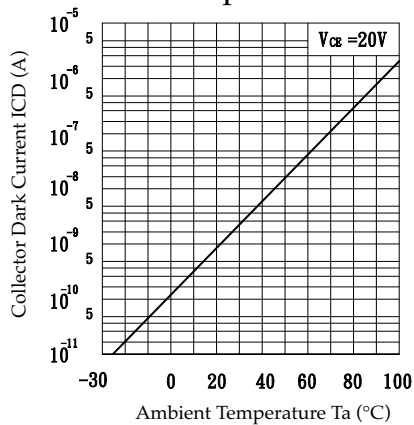

Response Time vs. Load Resistance

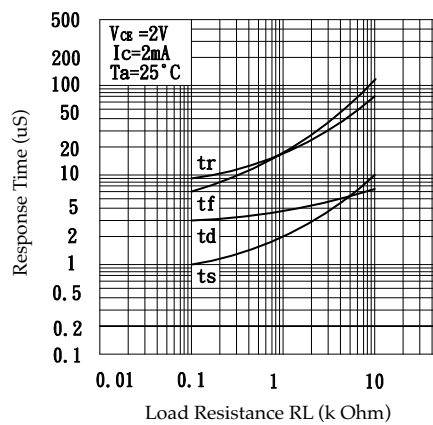

REELING INFORMATION

The AMC181 High Voltage Opto Coupler is available in either bulk or reeled format.

The standard reel size is 2,000 components per reel, and both left hand and right hand reel formats are available.

The difference between Left and Right hand reels is illustrated below :

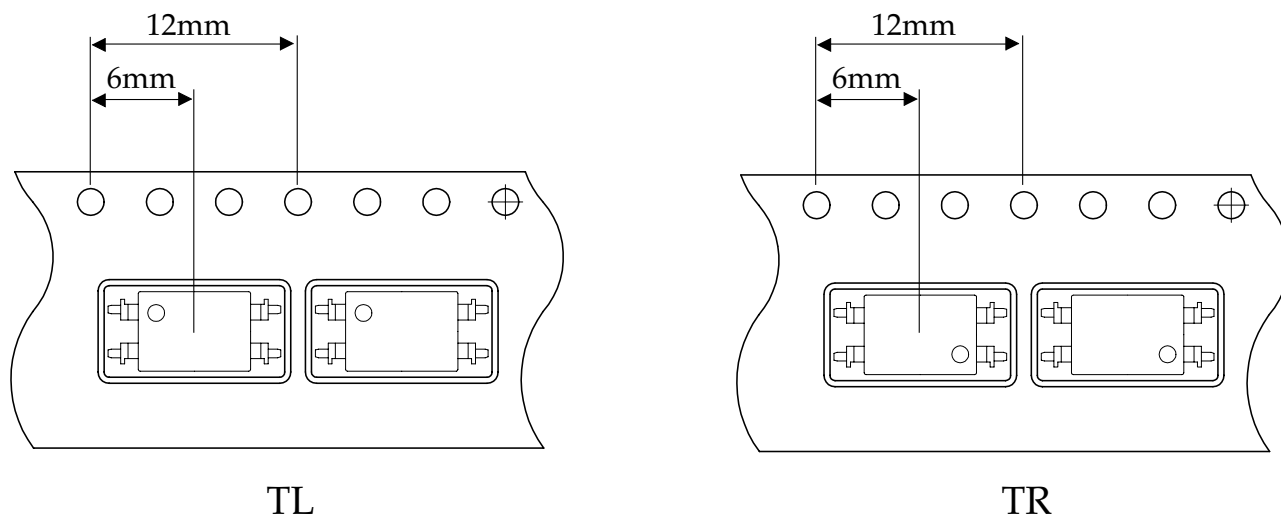

For further details on this product contact :

ALPHA MICRO
c o m p o n e n t s

Alpha Micro Components Ltd.
Springfield House
Cranes Road
Sherborne St. John
Basingstoke
Hampshire
RG24 9LJ. UK

Tel: 01256 851770 (International +44 1256 851770)
Fax: 01256 851771 (International +44 1256 851771)

e-mail : sales@alphamicro.net
<http://www.alphamicro.net>